

CHAPTER 26

GENERAL PLUMBING REQUIREMENTS

SECTION P2601 GENERAL

P2601.1 Scope. The provisions of this chapter shall govern the installation of plumbing not specifically covered in other chapters applicable to plumbing systems. The installation of plumbing, *appliances*, *equipment* and systems not addressed by this code shall comply with the applicable provisions of the *International Plumbing Code*.

P2601.2 Connections. Plumbing fixtures, drains and appliances used to receive or discharge liquid wastes or sewage shall be directly connected to the sanitary drainage system of the building or premises, in accordance with the requirements of this code. This section shall not be construed to prevent indirect waste systems.

Exception: Bathtubs, showers, lavatories, clothes washers and laundry trays are not required to discharge to the sanitary drainage system where those fixtures discharge to an approved gray water or rain water recycling system.

P2601.3 Flood hazard area. In areas prone to flooding as established by Table R301.2(1), plumbing fixtures, drains, and *appliances* shall be located or installed in accordance with Section R322.1.6.

SECTION P2602 INDIVIDUAL WATER SUPPLY AND SEWAGE DISPOSAL

P2602.1 General. The water and drainage system of any building or premises where plumbing fixtures are installed shall be connected to a public or private water supply and a public or private sewer system. As provided for in Section 103.11 of Part I of the *Virginia Uniform Statewide Building Code* (13 VAC 5-63) for functional design, water supply sources and sewage disposal systems are regulated and approved by the Virginia Department of Health and the Virginia Department of Environmental Quality.

Note: See also the Memorandums of Agreement in the "Related Laws Package," which is available from the Virginia Department of Housing and Community Development.

P2602.2 Flood-resistant installation. In areas prone to flooding as established by Table R301.2(1):

1. Water supply systems shall be designed and constructed to prevent infiltration of floodwaters.
2. Pipes for sewage disposal systems shall be designed and constructed to prevent infiltration of floodwaters into the systems and discharges from the systems into floodwaters.

SECTION P2603 STRUCTURAL AND PIPING PROTECTION

P2603.1 General. In the process of installing or repairing any part of a plumbing and drainage installation, the finished floors, walls, ceilings, tile work or any other part of the building or premises that must be changed or replaced shall be left in a safe structural condition in accordance with the requirements of the building portion of this code.

P2603.2 Drilling and notching. Wood-framed structural members shall not be drilled, notched or altered in any manner except as provided in Sections R502.8, R602.5, R602.6, R802.7 and R802.7.1. Holes in load-bearing members of cold-formed steel light-frame construction shall be permitted only in accordance with Sections R505.3.5, R603.2.5 and R804.2.5. In accordance with the provisions in Sections R505.3.5, R603.3.4 and R804.3.4, cutting and notching of flanges and lips of load-bearing members of cold-formed steel light-frame construction shall not be permitted. Structural insulated panels (SIPs) shall be drilled and notched or altered in accordance with the provisions of Section R613.7.

P2603.2.1 Protection against physical damage. In concealed locations, where piping, other than cast-iron or galvanized steel, is installed through holes or notches in studs, joists, rafters or similar members less than 1½ inches (38 mm) from the nearest edge of the member, the pipe shall be protected by steel shield plates. Such shield plates shall have a thickness of not less than 0.0575 inch (1.463 mm) (No. 16 Gage). Such plates shall cover the area of the pipe where the member is notched or bored, and shall extend a minimum of 2 inches (51 mm) above sole plates and below top plates.

P2603.3 Breakage and corrosion. Pipes passing through or under walls shall be protected from breakage. Pipes passing through concrete or cinder walls and floors, cold-formed steel framing or other corrosive material shall be protected against external corrosion by a protective sheathing or wrapping or other means that will withstand any reaction from lime and acid of concrete, cinder or other corrosive material. Sheathing or wrapping shall allow for movement including expansion and contraction of piping. Minimum wall thickness of material shall be 0.025 inch (0.64 mm).

P2603.4 Sleeves. Annular spaces between sleeves and pipes shall be filled or tightly caulked as *approved* by the *building official*. Annular spaces between sleeves and pipes in fire-rated assemblies shall be filled or tightly caulked in accordance with the building portion of this code.

P2603.5 Pipes through footings or foundation walls. Any pipe that passes under a footing or through a foundation wall shall be provided with a relieving arch; or there shall be built into the masonry wall a pipe sleeve two pipe sizes greater than the pipe passing through.

GENERAL PLUMBING REQUIREMENTS

P2603.6 Freezing. In localities having a winter design temperature of 32°F (0°C) or lower as shown in Table R301.2(1) of this code, a water, soil or waste pipe shall not be installed outside of a building, in exterior walls, in attics or crawl spaces, or in any other place subjected to freezing temperature unless adequate provision is made to protect it from freezing by insulation or heat or both. Water service pipe shall be installed not less than 12 inches (305 mm) deep and not less than 6 inches (152 mm) below the frost line.

P2603.6.1 Sewer depth. Building sewers that connect to private sewage disposal systems shall be a minimum of [NUMBER] inches (mm) below finished grade at the point of septic tank connection. Building sewers shall be a minimum of [NUMBER] inches (mm) below grade.

SECTION P2604 TRENCHING AND BACKFILLING

P2604.1 Trenching and bedding. Where trenches are excavated such that the bottom of the trench forms the bed for the pipe, solid and continuous load-bearing support shall be provided between joints. Where over-excavated, the trench shall be backfilled to the proper grade with compacted earth, sand, fine gravel or similar granular material. Piping shall not be supported on rocks or blocks at any point. Rocky or unstable soil shall be over-excavated by two or more pipe diameters and brought to the proper grade with suitable compacted granular material.

P2604.2 Common trench. See Section P2905.4.2.

P2604.3 Backfilling. Backfill shall be free from discarded construction material and debris. Backfill shall be free from rocks, broken concrete and frozen chunks until the pipe is covered by at least 12 inches (305 mm) of tamped earth. Backfill shall be placed evenly on both sides of the pipe and tamped to retain proper alignment. Loose earth shall be carefully placed in the trench in 6-inch (152 mm) layers and tamped in place.

P2604.4 Protection of footings. Trenching installed parallel to footings shall not extend below the 45-degree (0.79 rad) bearing plane of the bottom edge of a wall or footing (see Figure P2604.4).

SECTION P2605 SUPPORT

P2605.1 General. Piping shall be supported in accordance with the following:

1. Piping shall be supported to ensure alignment and prevent sagging, and allow movement associated with the expansion and contraction of the piping system.
2. Piping in the ground shall be laid on a firm bed for its entire length, except where support is otherwise provided.
3. Hangers and anchors shall be of sufficient strength to maintain their proportional share of the weight of pipe and contents and of sufficient width to prevent distortion to the pipe. Hangers and strapping shall be of approved material that will not promote galvanic action. Rigid sup-

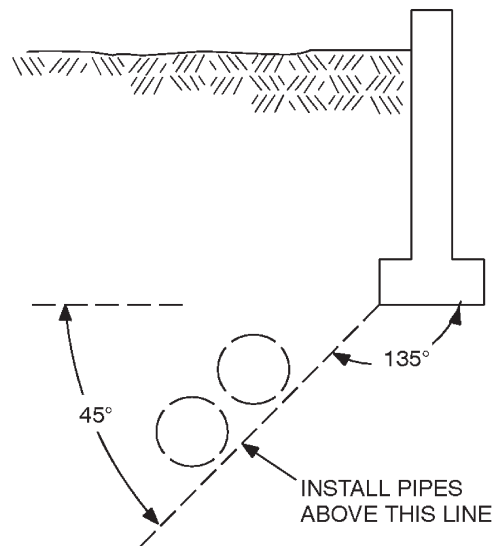

For SI: 1 degree = 0.018 rad.

**FIGURE P2604.4
PIPE LOCATION WITH RESPECT TO FOOTINGS**

port sway bracing shall be provided at changes in direction greater than 45 degrees (0.79 rad) for pipe sizes 4 inches (102 mm) and larger.

4. Piping shall be supported at distances not to exceed those indicated in Table P2605.1.

SECTION P2606 WATERPROOFING OF OPENINGS

P2606.1 General. Roof and exterior wall penetrations shall be made water tight. Joints at the roof, around vent pipes, shall be made water tight by the use of lead, copper or galvanized iron flashings or an approved elastomeric material. Counterflashing shall not restrict the required internal cross-sectional area of any vent.

SECTION P2607 WORKMANSHIP

P2607.1 General. Valves, pipes and fittings shall be installed in correct relationship to the direction of the flow. Burred ends shall be reamed to the full bore of the pipe.

SECTION P2608 MATERIALS EVALUATION AND LISTING

P2608.1 Identification. Each length of pipe and each pipe fitting, trap, fixture, material and device used in a plumbing system shall bear the identification of the manufacturer.

P2608.2 Installation of materials. All materials used shall be installed in strict accordance with the standards under which the materials are accepted and approved. In the absence of such installation procedures, the manufacturer's installation instructions shall be followed. Where the requirements of referenced standards or manufacturer's installation instructions do not

conform to the minimum provisions of this code, the provisions of this code shall apply.

P2608.3 Plastic pipe, fittings and components. All plastic pipe, fittings and components shall be third-party certified as conforming to NSF 14.

P2608.4 Third-party testing and certification. All plumbing products and materials shall comply with the referenced standards, specifications and performance criteria of this code and shall be identified in accordance with Section P2608.1. Where required by Table P2608.4, plumbing products and materials shall either be tested by an *approved* third-party testing agency or certified by an *approved* third-party certification agency.

P2608.5 Water supply systems. Water service pipes, water distribution pipes and the necessary connecting pipes, fittings, control valves, faucets and all appurtenances used to dispense water intended for human ingestion shall be evaluated and listed as conforming to the requirements of NSF 61.

**TABLE P2605.1
PIPING SUPPORT**

PIPING MATERIAL	MAXIMUM HORIZONTAL SPACING (feet)	MAXIMUM VERTICAL SPACING
ABS pipe	4	10 ^b
Aluminum tubing	10	15
Brass pipe	10	10
Cast-iron pipe	5 ^a	15
Copper or copper alloy pipe	12	10
Copper or copper alloy tubing (1 ¹ / ₄ inch diameter and smaller)	6	10
Copper or copper alloy tubing (1 ¹ / ₂ inch diameter and larger)	10	10
Cross-linked polyethylene (PEX) pipe	2.67 (32 inches)	10 ^b
Cross-linked polyethylene/aluminum/cross-linked polyethylene (PEX-AL-PEX) pipe	2.67 (32 inches)	4 ^b
CPVC pipe or tubing (1 inch in diameter and smaller)	3	10 ^b
CPVC pipe or tubing (1 ¹ / ₄ inch in diameter and larger)	4	10 ^b
Lead pipe	Continuous	4
PB pipe or tubing	2.67 (32 inches)	4
Polyethylene/aluminum/polyethylene (PE-AL-PE) pipe	2.67 (32 inches)	4 ^b
Polypropylene (PP) pipe or tubing 1 inch and smaller	2.67 (32 inches)	10 ^b
Polypropylene (PP) pipe or tubing, 1 ¹ / ₄ inches and larger	4	10 ^b
PVC pipe	4	10 ^b
Stainless steel drainage systems	10	10 ^b
Steel pipe	12	15

For SI: 1 inch = 25.4 mm, 1 foot = 304.8 mm.

a. The maximum horizontal spacing of cast-iron pipe hangers shall be increased to 10 feet where 10-foot lengths of pipe are installed.

b. Midstory guide for sizes 2 inches and smaller.

GENERAL PLUMBING REQUIREMENTS

**TABLE P2608.4
PRODUCTS AND MATERIALS REQUIRING THIRD-PARTY TESTING AND THIRD-PARTY CERTIFICATION**

PRODUCT OR MATERIAL	THIRD-PARTY CERTIFIED	THIRD-PARTY TESTED
Backflow prevention devices	Required	—
Plumbing appliance	Required	—
Plumbing fixtures	—	Required
Potable water supply system components and potable water fixture fittings	Required	—
Sanitary drainage and vent system components	Plastic pipe, fittings, and pipe related components	All others
Special waste system components	—	Required
Storm drainage system components	Plastic pipe, fittings, and pipe related components	All others
Subsoil drainage system components	—	Required
Waste fixture fittings	Plastic pipe, fittings, and pipe related components	All others
Water distribution system safety devices	Required	—